

NITCHI

NITCHI ELECTRIC CHAIN HOIST

MODELS
EC4/ECT4/ECC4/ECE4/ECG4/ECP4

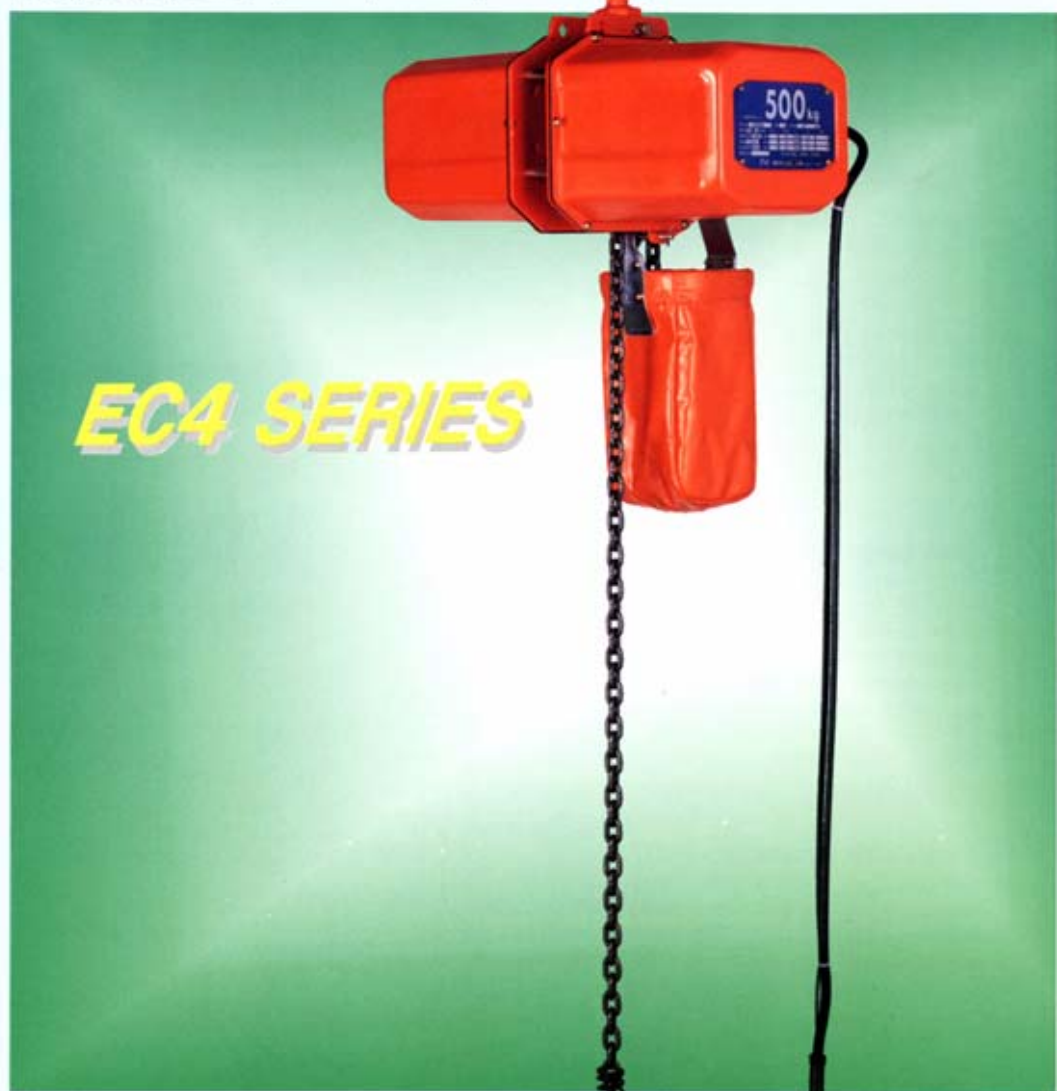

EC4 SERIES



manufactured by

NITCHI CO., LTD.

OSAKA, JAPAN

NITCHI EC4 Series electric chain hoists

The efficient, economical hoists you can rely on.

Wear Resisting Load Sheave

The special load sheaves engage precisely with the load chains and are specially thermo-refined to make them long wearing.

Heavy Duty Motor

The Class "B" (ECC4 Class "E") insulation of the high performance motors are capable of handling most materials handling applications.

First Stage Helical Gearing

The precision helical gears in the first stage of the reduction gear system largely reduce gear tooth impact and the operating vibrations, and is one of the main factors for the quiet long dependable life of the EC4 Series.

Easy Cable Couplings - NEW!!

The new Easy Cable Coupling system makes it possible to easily and quickly to attach, detach or replace the pendant and cables.

Push Button Switch

The strong light-weight push button switch responds immediately and can be operated with a light touch of the button.

Chain Bucket

Each hoist is supplied with a chain bucket as standard equipment.

Forged Steel Hooks

The top and bottom hooks on all capacities are made of drop-forged steel that is heat-treated for greater strength. Every bottom hook is equipped with a thrust bearing for smooth rotating to all directions and has a latch as standard equipment.

Space Age Materials - NEW!!

The remarkably durable lightweight resinoid center-frame and cover provide tight fits that notably improve dust and moisture protection, and assist to lower operating noises.

Steel Construction

The two rugged steel plates main frame provides maximum protection against dynamic loads.

Ultra-Tough Load Chains

The NITCHI case hardened load chains are made from special alloy steel, and are given super-tough carbonized hard surfaces that resist erosion several times longer than conventional through hardened load chains. The soft core section gives the load chain the elasticity which is essential for material lifting equipment. Every link of load chain is tested, and a record of each chain production lot is kept on record at our factory.

Super tough carbonized hard surface

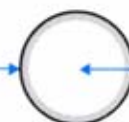

Soft core

Cross section of chain link

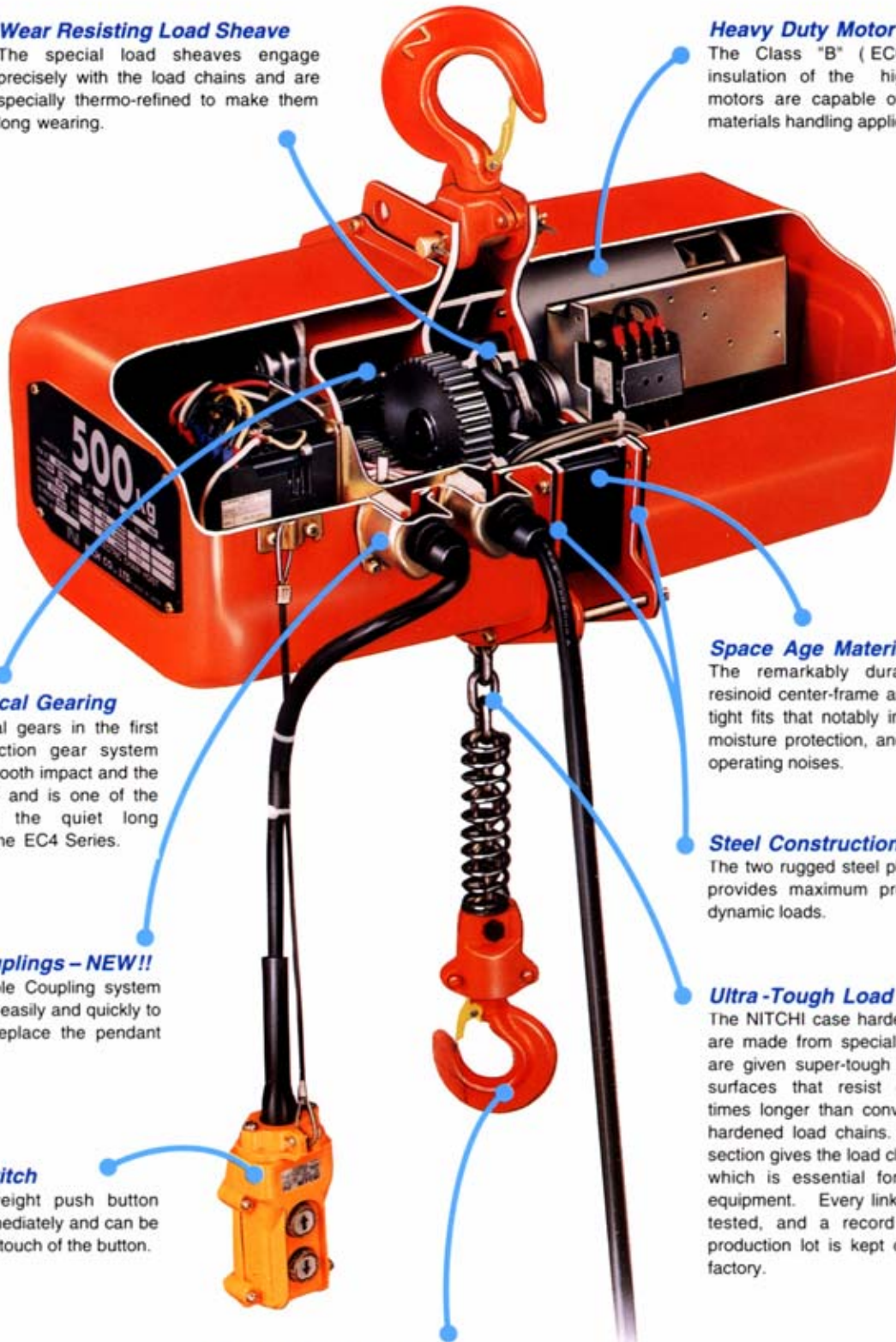

Moisture and Dust Protection – IMPROVE!

The **IP54** protection of the hoist bodies and the **IP64** protection of the push button switch are more than adequate for most applications that demand for moisture and dust protection.

Quiet and Smooth Operation – IMPROVED!

The **helical gears** on the first stage of the reduction gears lower vibrations and noise levels remarkably. When compared to the former EC-3M Series, the noise levels of the EC4 Series are **3 to 10 Decibels lower!**

Over Lifting and Over lowering LIMIT SWITCH– IMPORTANT!!!

The over lifting and over lowering limit switch system is one of the most important safety devices on an electric chain hoist, which can not be substituted with micro switches that rely on the over load protection device. The EC4 Series are equipped with what we believe is the most efficient and reliable limit switch system available for electric chain hoists, which functions completely independent of the overload protection.

- A. Buffer Springs** located on both ends of the load chain absorb the initial shock and allow the limit switch to function before the hoist is under substantial force.
- B. Limit Lever** is the mechanical actuator, which positively activates the limit switch system when the hoist are over lifted or over lowered.
- C. Limit Switch** instantly stops the hoist when over lifting or over lowering.

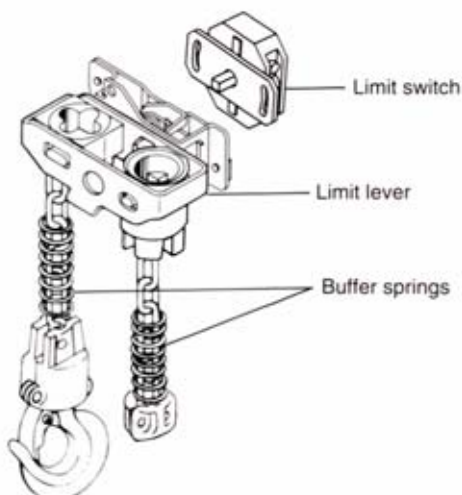

High ED Percent Rating

Model	ED %
EC4 (1- speed type)	40%
ECT4 (2- speed type)	25%
ECC4 (single phase type)	25%

Durable Brake

The solenoid brake system responds instantly and will safely support the load during power failures. This brake system has proven to be extremely long wearing and will keep servicing costs down.

Electro-Magnetic Controlled (EC4 & ECT4) – IMPORT!!!

Models EC4 (1-speed type) and ECT4 (2-speed type) are electro-magnetic controlled with 24-volt, and will protect the operator from harmful electrical shocks.

Short Head Room

The ingeniously designed compact construction permits the highest possible lift where the last inch of lift must be obtained - compare the difference with equivalent models.

Remarkable Durability

The EC4 Series is designed and made to Grade M4 of Japanese Industrial Standard (JIS) B8815-1994 Electric Chain Hoist.

Easy Servicing

The robust steel design gives easy access to all of the major mechanical and electrical components, which simplifies inspection, maintenance and the replacement of components.

Useful Operation Manual

With each hoist is supplied a comprehensive operation manual providing sufficient instructions and information on installation, operation and maintenance with illustrated parts list.

Optional Equipment

The following optional equipment are available at modest extra charges:-

- A. Electric type over load protection
- B. Friction type over load protection
- C. Negative Phase protection
(Warning system to prevent incorrect connection of the power source)
- D. Push button switch with emergency stop
- E. NN Case hardened Chain
(Non-electrolytic nickel plating fused into the surface of the chain)

1-Speed Electric Chain Hoist / 2-Speed Electric C



EC4
500kg

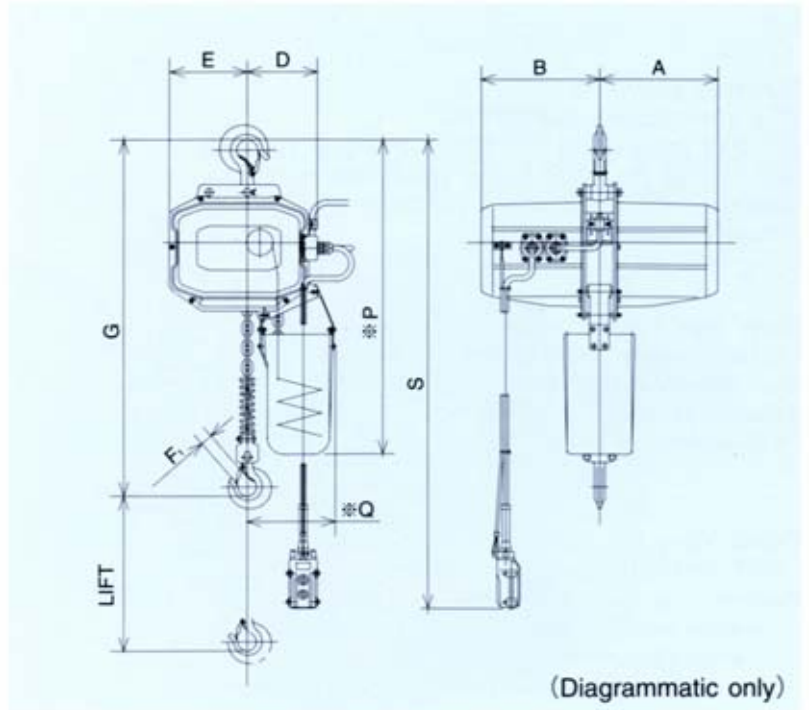

- EC4 250kg, 500kg & 1t
- ECT4 250kg, 500kg & 1t
- ECC4 300kg & 500kg

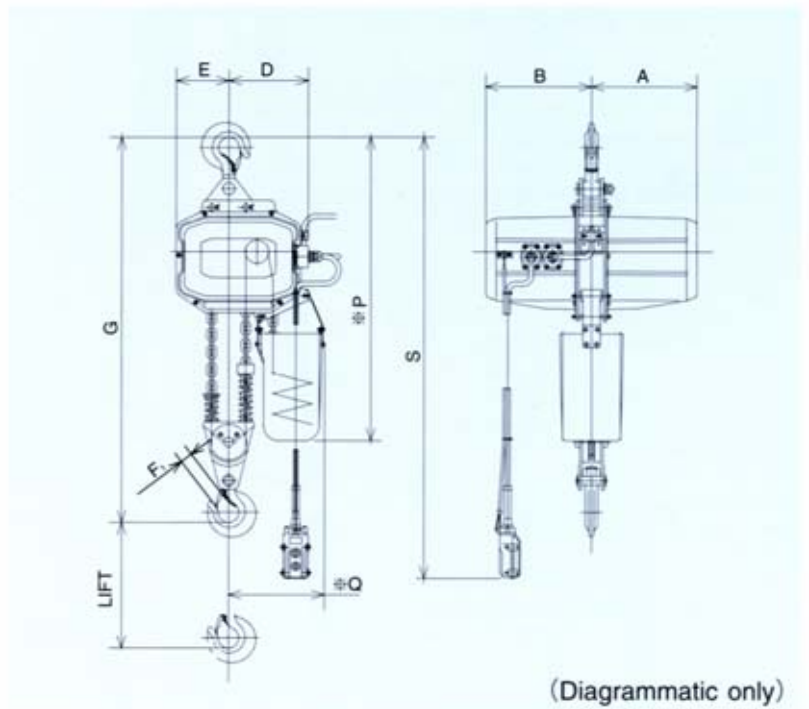

- EC4 1 t w & 2 t
- ECT4 1 t w & 2 t
- ECC4 1 t w

Chain Hoist / Single-Phase Electric Chain Hoist

EC4 (1-Speed)

One speed electric chain hoists are available in 5 different sizes ranging from light 250 kg to heavy 2 t capacities.

STANDARD SPECIFICATIONS: Model EC4 Suspended Type One speed Electric Chain Hoist

Item No.	Rated load	Lift (m)	Lifting Speed (m/min)		Motor output (kw)		Rating (min.)	Load chain		Cable Length		Minimum head room G (mm)	Net weight (approx.) # (kg)	Major Dimension (approx.) (mm)						
			50Hz	60Hz	50Hz	60Hz		Di. (mm)	No. of falls	Power Source (m)	Pendant S(m)			A	B	D	E	F ₁	#P	#Q
EC40025	250kg	3.0	8.7	10.3	0.4	0.5	30	6.3	1	5.0	2.6	485	35	245	245	137	149	20	660	195
		6.0									5.6		37							
EC40050	500kg	3.0	8.6	10.1	0.9	1.1	30	6.3	1	5.0	2.6	520	37	245	245	137	149	20	660	195
		6.0									5.6		41							
ECJ40100	1t w	3.0	4.3	5.0	0.9	1.1	30	6.3	2	5.0	2.6	660	43	245	245	167	119	25	715	225
		6.0									5.6		49							
EC40100	1t	3.0	5.6	6.6	1.1	1.3	30	7.1	1	5.0	2.6	570	49	255	255	150	168	25	710	200
		6.0									5.6		52							
ECJ40200	2t	3.0	2.8	3.3	1.1	1.3	30	7.1	2	5.0	2.6	755	58	255	255	191	127	30	770	240
		6.0									5.6		65							

- The values marked # are valid for the standard 3 meter lift and will vary in accordance with the lift.
- The design, materials and specifications are subject to change for improvements without notice.

ECT4 (2-Speed)

Two speed electric chain hoists are also available in 5 different capacities ranging from 250 kg to 2t. The 4 to 1 speed ratio of Model ECT4 is ideal for a large variety of applications...no more cumbersome inching, the slow speed works accurately when spotting the load to a desired position, and with the fast speed the load can be quickly and efficiently handled. The slow and fast speeds are both completely at your command with the dual-stage push button switch. For slow speed press the buttons halfway down, and the fast speed can be obtained by completely depressing the buttons.

STANDARD SPECIFICATIONS: Model ECT4 Suspended Type Two speed Electric Chain Hoist

Item No.	Rated load	Lift (m)	Lifting Speed (m/min)				Motor output (kw)				Rating (min.)		Load chain		Cable Length		Minimum head room G (mm)	Net weight (approx.) # (kg)	Major Dimension (approx.) (mm)						
			Fast		Slow		Fast		Slow		Fast	Slow	Di. (mm)	No. of falls	Power Source (m)	Pendant S(m)			A	B	D	E	F ₁	#P	#Q
			50Hz	60Hz	50Hz	60Hz	50Hz	60Hz	50Hz	60Hz															
ECT40025	250kg	3.0	8.7	10.3	2.2	2.6	0.4	0.5	0.1	0.13	30	10	6.3	1	5.0	2.6	485	37	245	245	137	149	20	660	195
		6.0														5.6		40							
ECT40050	500kg	3.0	8.6	10.1	2.2	2.6	0.9	1.1	0.23	0.28	30	10	6.3	1	5.0	2.6	520	41	245	245	137	149	20	660	195
		6.0														5.6		44							
ECTJ40100	1t w	3.0	4.3	5.1	1.1	1.3	0.9	1.1	0.23	0.28	30	10	6.3	2	5.0	2.6	660	47	245	245	167	119	25	715	225
		6.0														5.6		52							
ECT40100	1t	3.0	5.6	6.7	1.4	1.7	1.1	1.3	0.27	0.33	30	10	7.1	1	5.0	2.6	570	54	255	255	150	168	25	710	200
		6.0														5.6		58							
ECTJ40200	2t	3.0	2.8	3.3	0.7	0.8	1.1	1.3	0.27	0.33	30	10	7.1	2	5.0	2.6	755	63	255	255	191	127	30	770	240
		6.0														5.6		70							

- The values marked # are valid for the standard 3 meter lift and will vary in accordance with the lift.
- The design, materials and specifications are subject to change for improvements without notice.
- Refer to page 5 & 6 for the specifications of the trolleys.

ECC4 (Single-Phase)

Single phase electric chain hoists are available for 300 kg, 500 kg and 1t w capacities. Model ECC4 is specially designed and manufactured for the efficient handling of loads on household power sources. N.B. Low voltage control optional extra.

STANDARD SPECIFICATIONS: Model ECC4 Suspended Type Single Phase Electric Chain Hoist

Item No.	Rated load	Lift (m)	Lifting Speed (m/min)		Motor output (kw)		Rating (min.)	Load chain		Cable Length		Minimum head room G (mm)	Net weight (approx.) # (kg)	Major Dimension (approx.) (mm)						
			50Hz	60Hz	50Hz	60Hz		Di. (mm)	No. of falls	Power Source (m)	Pendant S(m)			A	B	D	E	F ₁	#P	#Q
ECC40030	300kg	3.0	5.4	6.4	0.4	0.4	15	6.3	1	5.0	2.6	485	36	245	245	137	149	20	660	195
ECC40050	500kg		3.2	3.8								520	36							
ECCJ40100	1t w		1.6	1.9								660	42							

- The values marked # are valid for the standard 3 meter lift and will vary in accordance with the lift.
- The design, materials and specifications are subject to change for improvements without notice.
- Refer to page 5 & 6 for the specifications of the trolleys.

